

# About the use of drawing dies for shaped wire

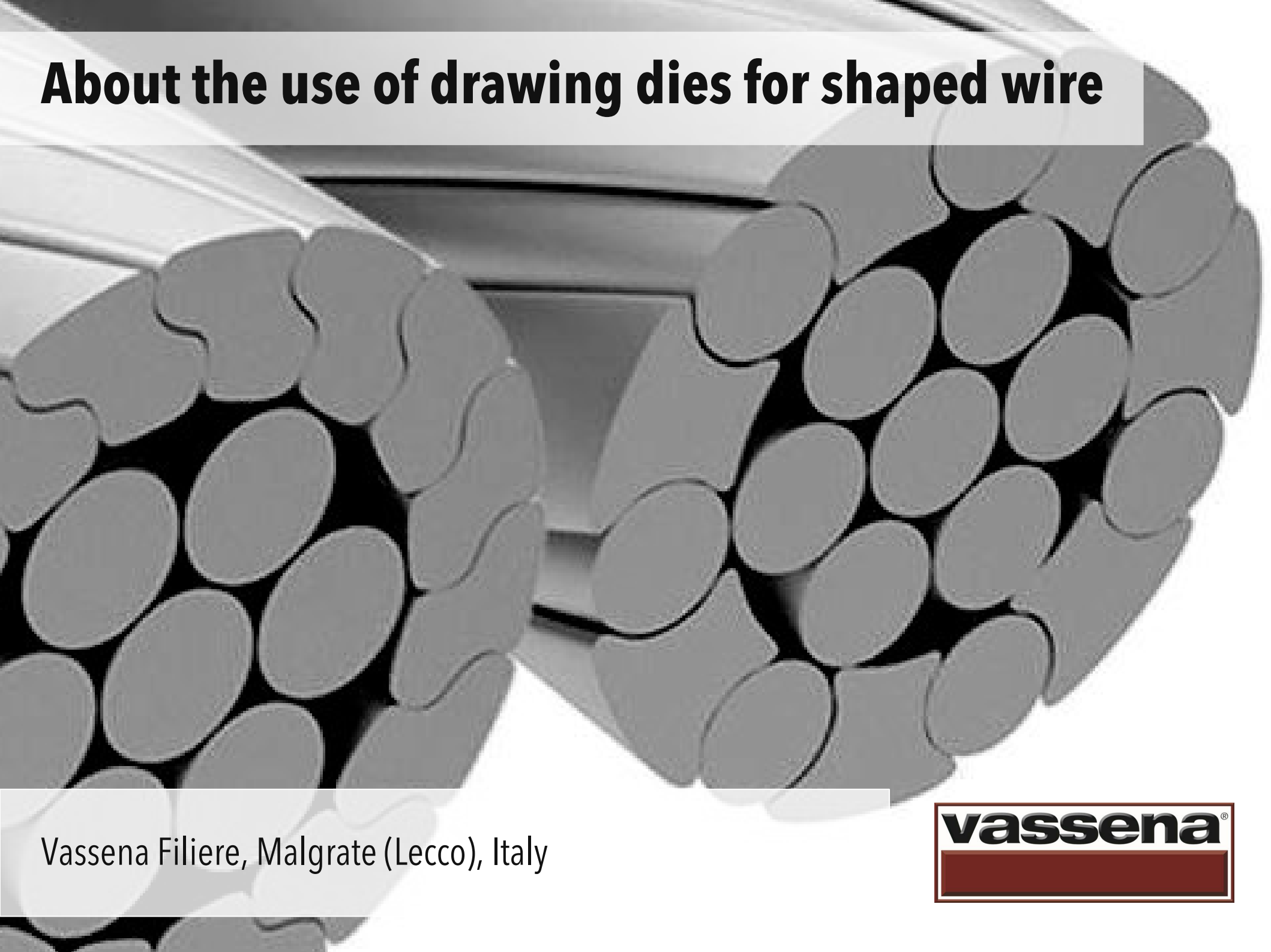

Vassena Filiere, Malgrate (Lecco), Italy



# Drawing as alternative to rolling

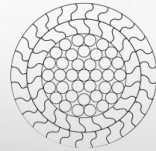

*"Rolling is the technical process of transforming the cross section of a wire making it pass through a set of rotationally symmetric tools called rolls."*

Instead of rolling, drawing with dies with long reduction cone causes the molecules to undergo a more homogeneous yield and a lower stress.

> The wire you get has a higher resistance than in rolling



# A longer reduction zone

Dies with longer reduction cone having minor inclination are less exposed to friction and die wear. They ensure:

- Better coverage of lubricant on wire
- Longer die life
- Higher drawing speeds
- Less friction
- Less energy consumption
- Better end quality

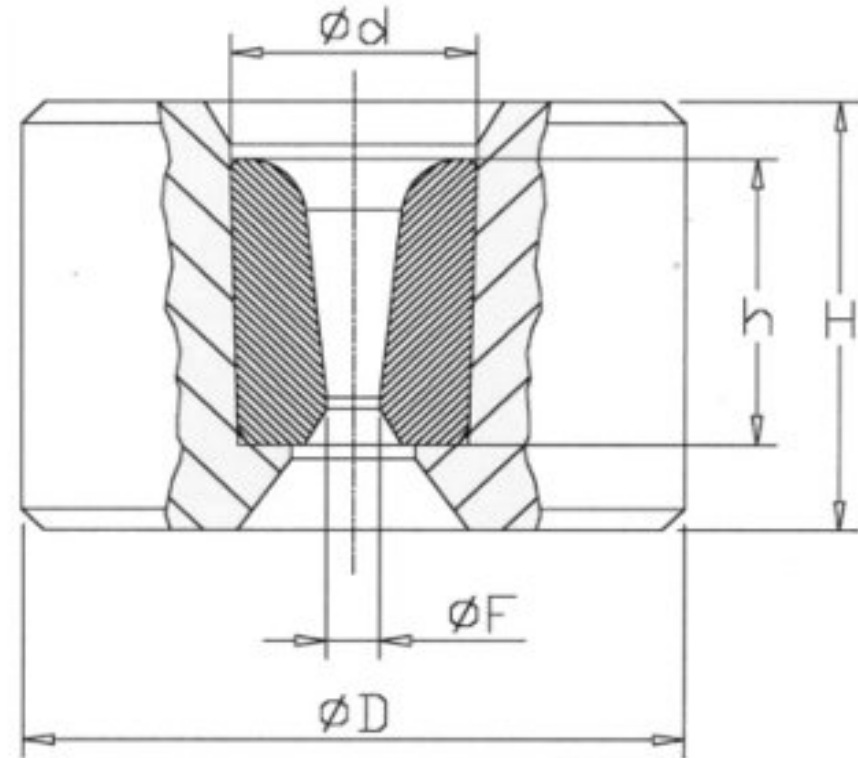

> Drawing dies type L

# Pressure dies

Using a pressure die increases lubricant pressure and drawing speed.

The particular geometry of the pressure core guarantees efficiency and constancy of lubrication, allowing to eliminate the solidification of the lubricant in the cone.

> What if we combine pressure dies with dies having a long reduction cone?

# Pressure die + long reduction cone

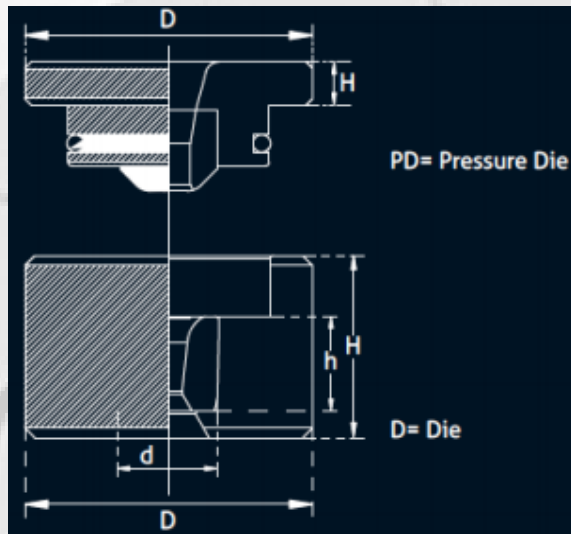

+

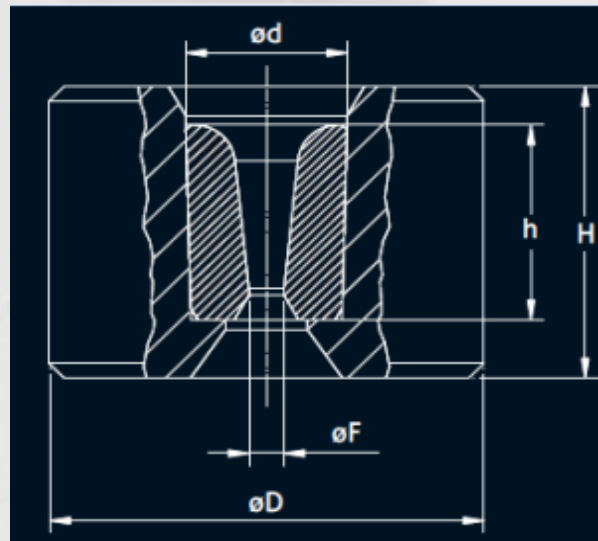

=



> VG402R.1 + Type L NIB

# Shaped wire drawing dies with variable conicity

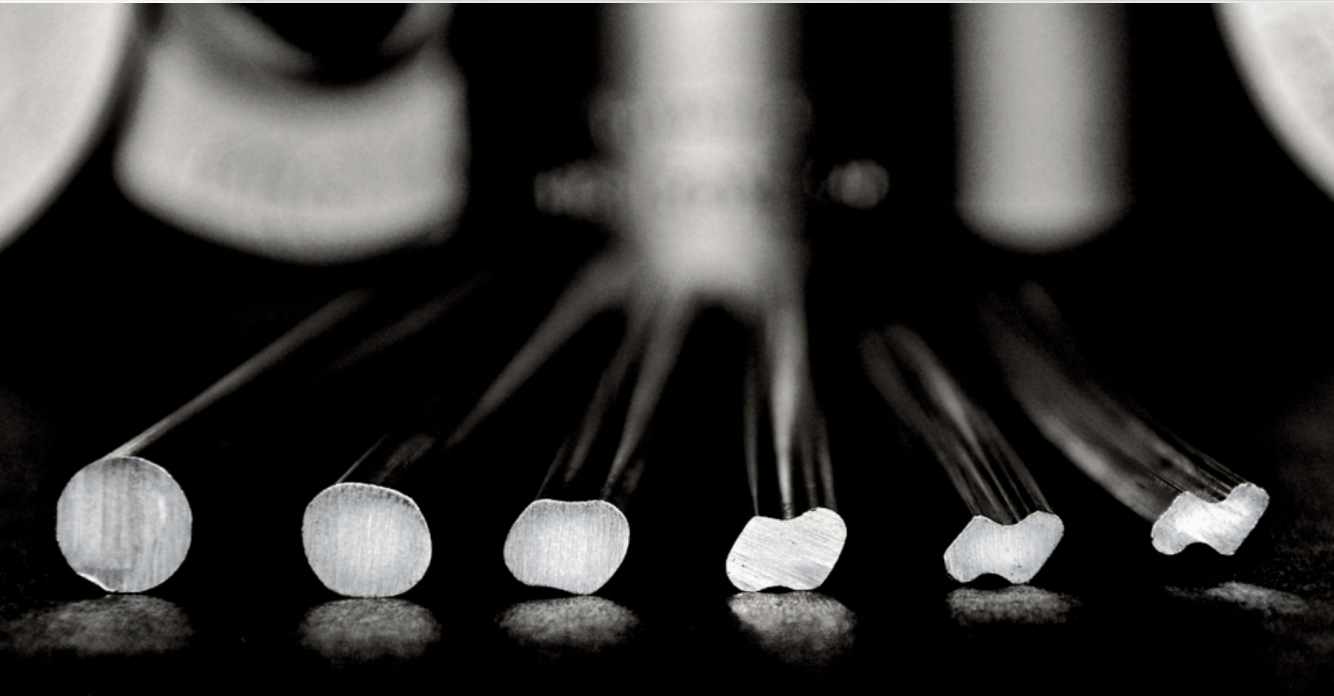

Vassena developed a system with variable conicity that allows the wire to have the same plastic deformation as in round wire drawing



## **More products from Vassena srl:**

Dies and pressure dies | Round dies | Shaped dies | Bushes | Sliding blocks  
Grinding machines for dies | Auxiliary equipment | and much more...

[www.vassena.it](http://www.vassena.it)

